

DESIGN COMPETITION:

27th Street Business District To Enhance It's Image

The S. 27th Street Business district extending from Oklahoma Avenue to College Avenue will see changes in 2010. The S. 27th Street Business Association has been working this past year with the State of Wisconsin Department of Transportation to develop a streetscape plan for the area. The plan focuses on a family of decorative signs directing people to the business district, street signs, colorful banners and median landscaping.

The goal of the streetscape project is to develop a "brand", an easily identifiable graphic that will be utilized on a number of signs throughout the business district. The S. 27th Street Business Association is conducting a community wide contest to develop two distinctive graphic designs for the district. The Business Association has identified a "Historic Route 41" theme as one way to add a special identity to the business district but other themes will be considered.

Area residents, artists and interested parties will have a chance during the next two months to develop artwork that can be reproduced on the signs, banners and monuments that will be constructed in the medians of S. 27th Street and Layton Avenue. *Advertising, religious or political messages are not allowed as part of the design.*

MONUMENT ELEVATION & WAYFINDING ELEVATION

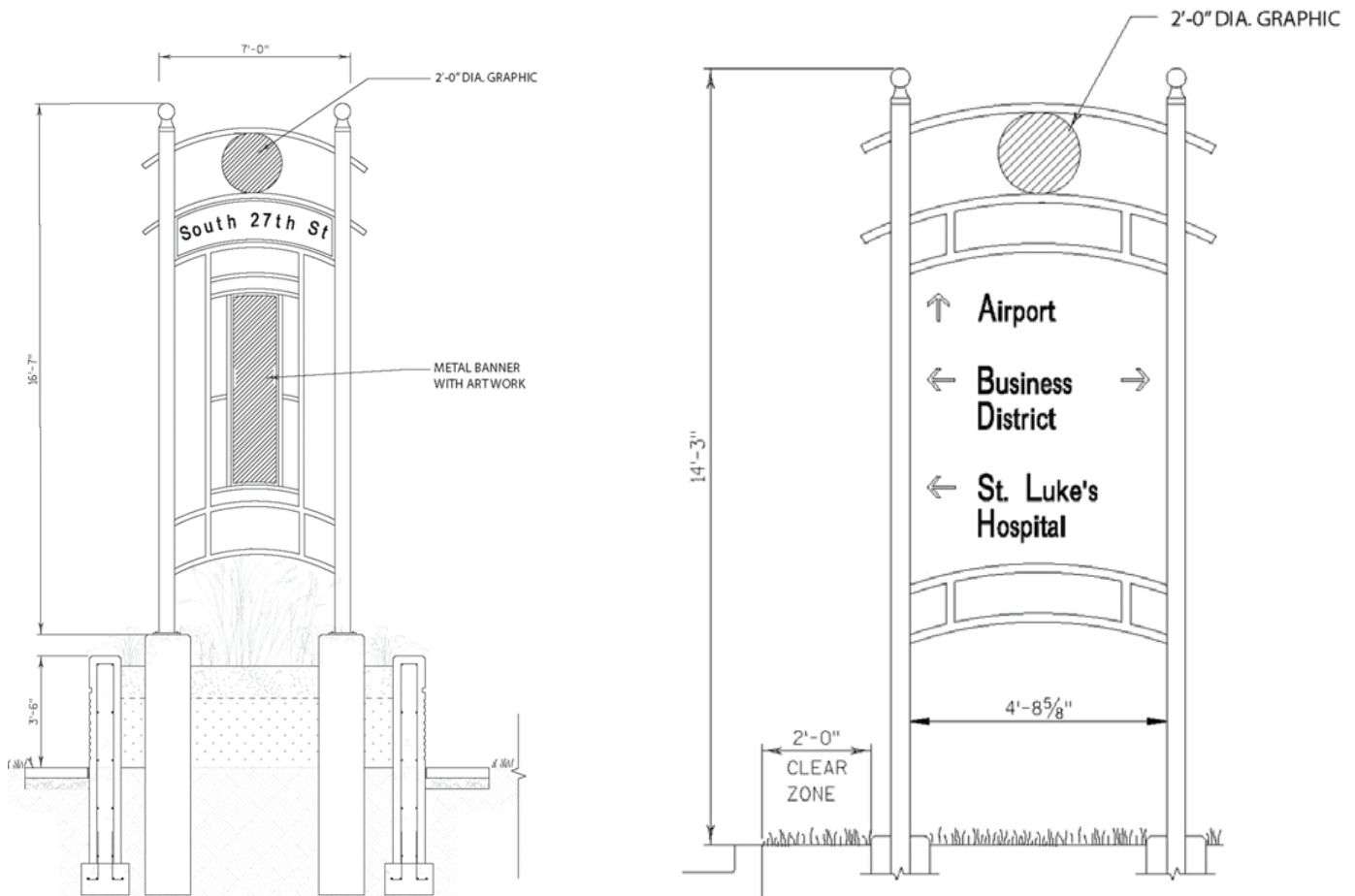

GRAPHIC 1

This graphic will be used on two different signs along S. 27th Street (see previous page). The signs are made of aluminum sheeting. Any design must be able to be cut from a “stick on” film utilized by the sign manufacturer. Since the signs will be viewed by motorists traveling at 35-40 mph, simplicity of design will create a more easily recognizable image.

1. The graphic will be printed on a 2 foot diameter circle (see right).
2. Colors are limited to a maximum of four (4).
3. Verbiage is permitted as an integral part of the graphic.
4. The sign will be a two sided sign therefore, the graphic must work when viewed from both sides.
5. The design should end 2 inches from the edge to allow for mounting.

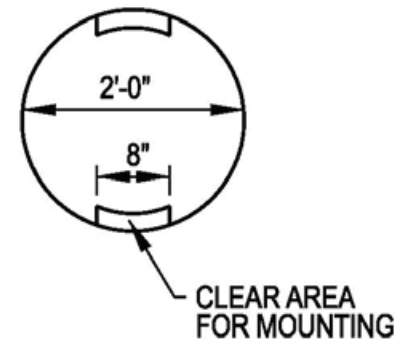

GRAPHIC 2

This graphic will be used also on pole mounted signs along S. 27th Street. These signs are made of aluminum sheeting. Any design must be able to be cut from a “stick on” film utilized by the sign manufacturer. Since the signs will be viewed by motorists traveling at 35-40 mph, simplicity of design will create a more easily recognizable image.

1. The graphic must fit on a 2 foot wide by 7 foot panel with an angled bottom (see right).
2. Colors are limited to a maximum of four (4).
3. 30% - 40% of each graphic must be a cut out area (void) that will create a silhouette design.
4. Verbiage is permitted as an integral part of the graphic.
5. The sign will be a two sided sign therefore, the graphic must work when viewed from both sides.
6. The design should end 2 inches from the edge to allow for mounting.
7. The overall design can be spread across two pole mounted signs if desired or the design can utilize only one sign with the pair of signs being mirror images of each other.
8. This design will also be used in the rectangular artwork portion of the gateway monument.

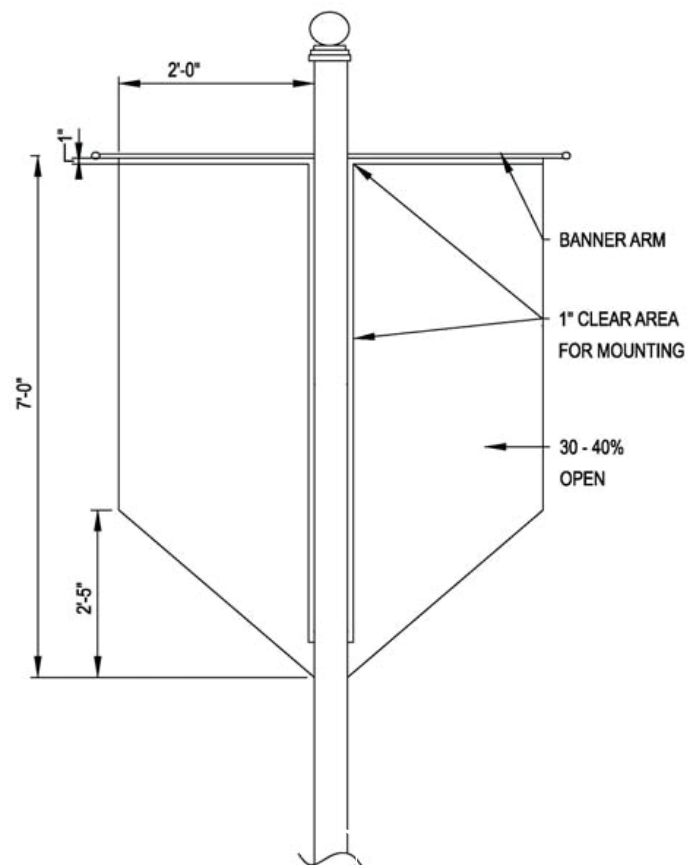

SUBMITTAL REQUIREMENTS

- The design should be colored and scaled. For example, a 2'x7' banner could be submitted at 6" by 1'-9." Hand drawings are acceptable as well as computer drawings.
- **Design Deadline: Tuesday June 30, 2009 by 3 p.m.**
- Submit designs in a sealed envelope with the entrants contact information in the envelope.
- For questions and submitting design contact:
Tara Cavazos, US Bank, 4333 S. 27th Street, Greenfield, WI 53221
(414) 282-3300

The Cities of Milwaukee and Greenfield and the S. 27th Street Business Association greatly appreciate the involvement of the community on this important project. The winning artist will be notified by mid-July. The City of Milwaukee and Greenfield will award a decorative plaque from the Common Councils recognizing the winning artist as a token of appreciation from the communities. In addition, a bronze plaque mounted on the median monument planter wall will display the artist's name and year designed.